



INTENSITY

NEXT GENERATION LED DRIVING LIGHTS

ARM476 -ARB Tube Mount Kit \varnothing 47.6mm (1.87in)

Kit Contents

| | |
|---|-------------------------|
| 2 x Inner Clamp – suit \varnothing 47.6 | 2 x ARB M6 Security Nut |
| 2 x Outer clamp – suit \varnothing 47.6 | 1 x ARB M6 Security Key |
| 2 x M6 x 35mm T-Bolt | |

Tools Required

- $\frac{1}{4}$ " spanner or ratchet with $\frac{1}{4}$ " hex drive
- Torque wrench (9 Nm / 80 lb-in)

NOTE: To prevent possibility of galling, lubricate bolt threads with a nickel or lanolin based lubricant such as Loctite® 771 or Lanotec™ before installing nuts.

Installation Instructions

1. Insert 2 x M6 x 35mm T-bolts into top channel in light bar.
2. Place 1 x inner clamp over each T-bolt and position over inner edge of light bar. Space T-bolts and clamps evenly about centre of light bar at a distance of between 210-420mm (8.4 - 16.5in).

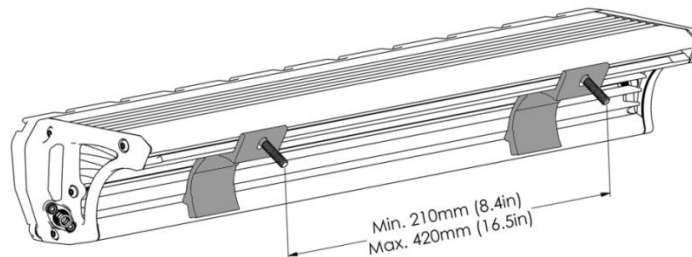

3. Place light bar against bull bar tube ensuring that inner clamps seat against tube. Position light bar centrally across bull bar.
4. Insert hook of each outer clamp into lower channel of light bar. Rotate clamps around tube and over T-bolts.

Note: Ensure light bar and clamps are correctly positioned before placement of outer clamps as clamps may mark tube when installed.

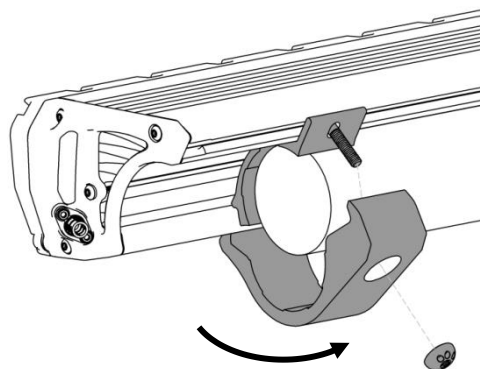

5. Lightly fasten light bar to tube by attaching supplied ARB M6 security nuts to T-bolts. Adjust rotation of light bar on tube to appropriate position and tighten security nuts using security key provided to 9 Nm / 80 lb-in.